



**System Management
Interface Forum**



**Power Management Bus
Implementers Forum**

PMBus™ – Coming To A Server Near You

Bob White

Chair, PMBus™ Specification Working Group

bob.white@ieee.org

www.pmbus.org

Presentation Overview

- PMBus™ Specification And Application Profiles
- PMBus In Today's Servers
- PMBus In Next Gen Servers
- New Energy Reading Commands
- Clarification Of Status Bits And SMBALERT# Signal
- Other Coming Updates

Disclaimer

Any Information About The Upcoming Revision Of The PMBus Specification And Application Profiles Is Preliminary And May Change Without Notice.

The PMBus Specification

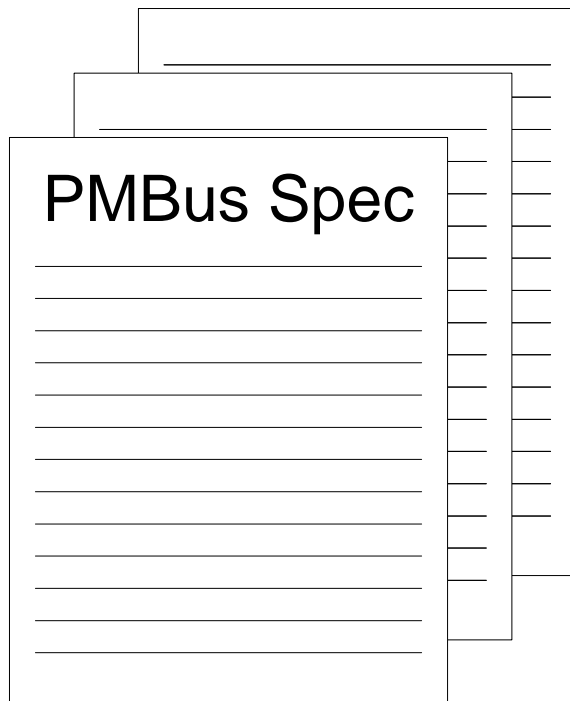

Revision 1.2
Coming Soon

- Includes
 - How Devices Communicate
 - Commands And Data
- Does Not Include
 - Application Specific Information
 - Required Commands
 - Tolerances

Application Profiles



- Includes
 - Required Commands
 - Required Data Formats
 - Required Data Ranges
 - Tolerances

Application Profile For
Server Power Coming
Soon After Specification
Revision 1.2

Server Power Application Profile

- Addressing
- Hardware
- Data Formats
 - Accuracy
 - VOUT_MODE
 - Sensor
 - Formatting Tables
- Monitoring Power/Current/Voltage
 - Sensor Sampling
- Thermal Management
- Status Commands
- Limit Commands
- Default Limits
- Manufacturer Controlled Limits
- Faults And Error Correction
- Capability And Inventory Reporting
- Write Protection
- Interrupts

PMBus In A Server

System Applications
Node Manger
Server Management

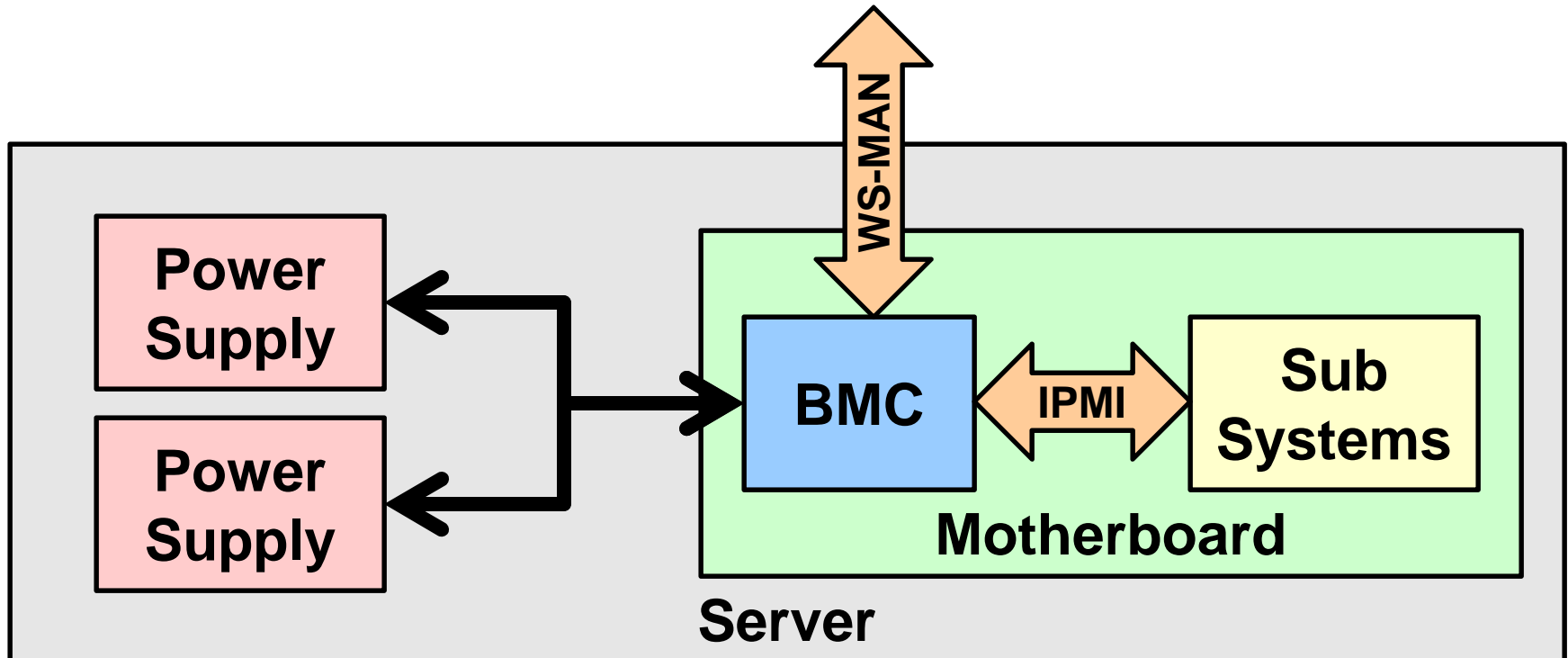

PMBus In A Server

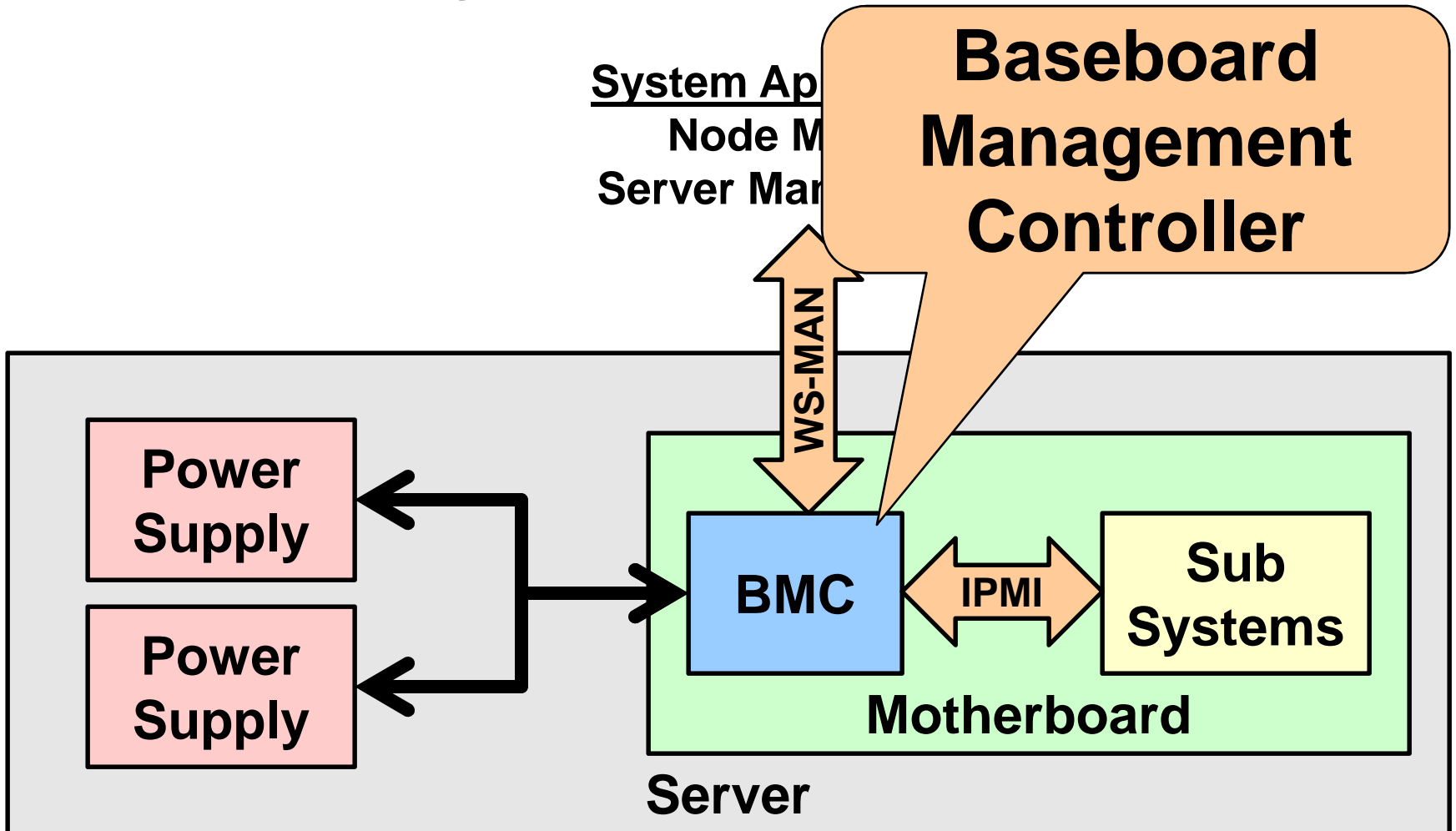

PMBus In A Server

System Applications
Node Manger
Server Management

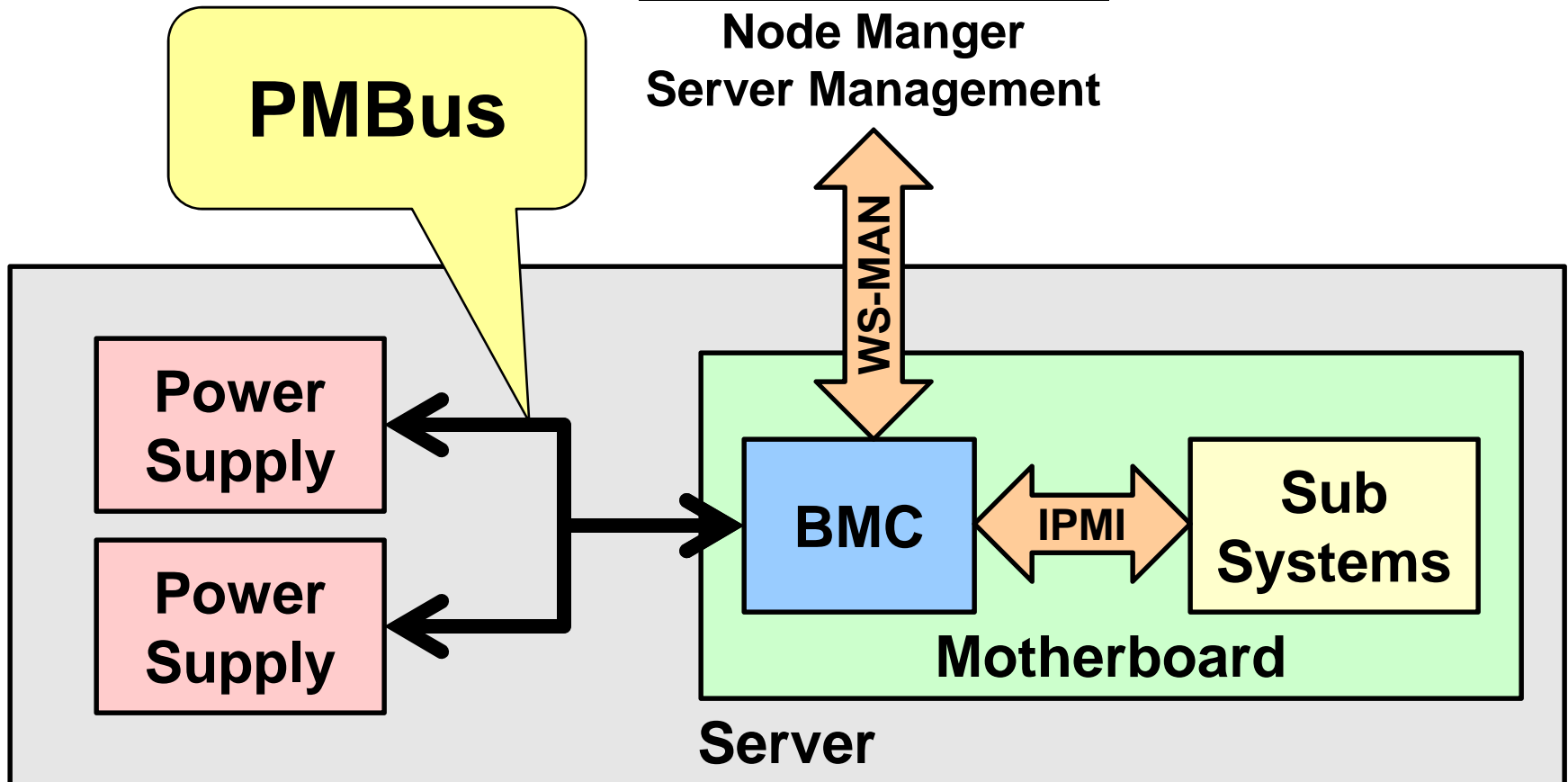

PMBus In A Server

PMBus Is Not Used To Communicate Outside The Server

System Applications
Node Manger
Server Management

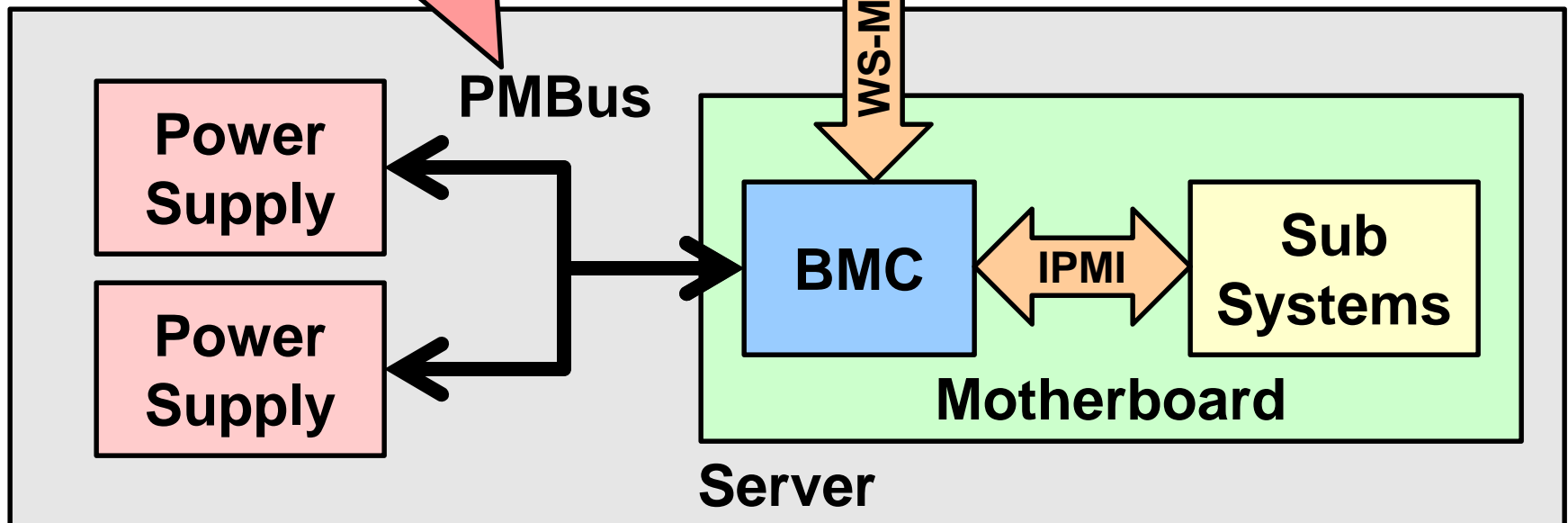

PMBus In Data Center

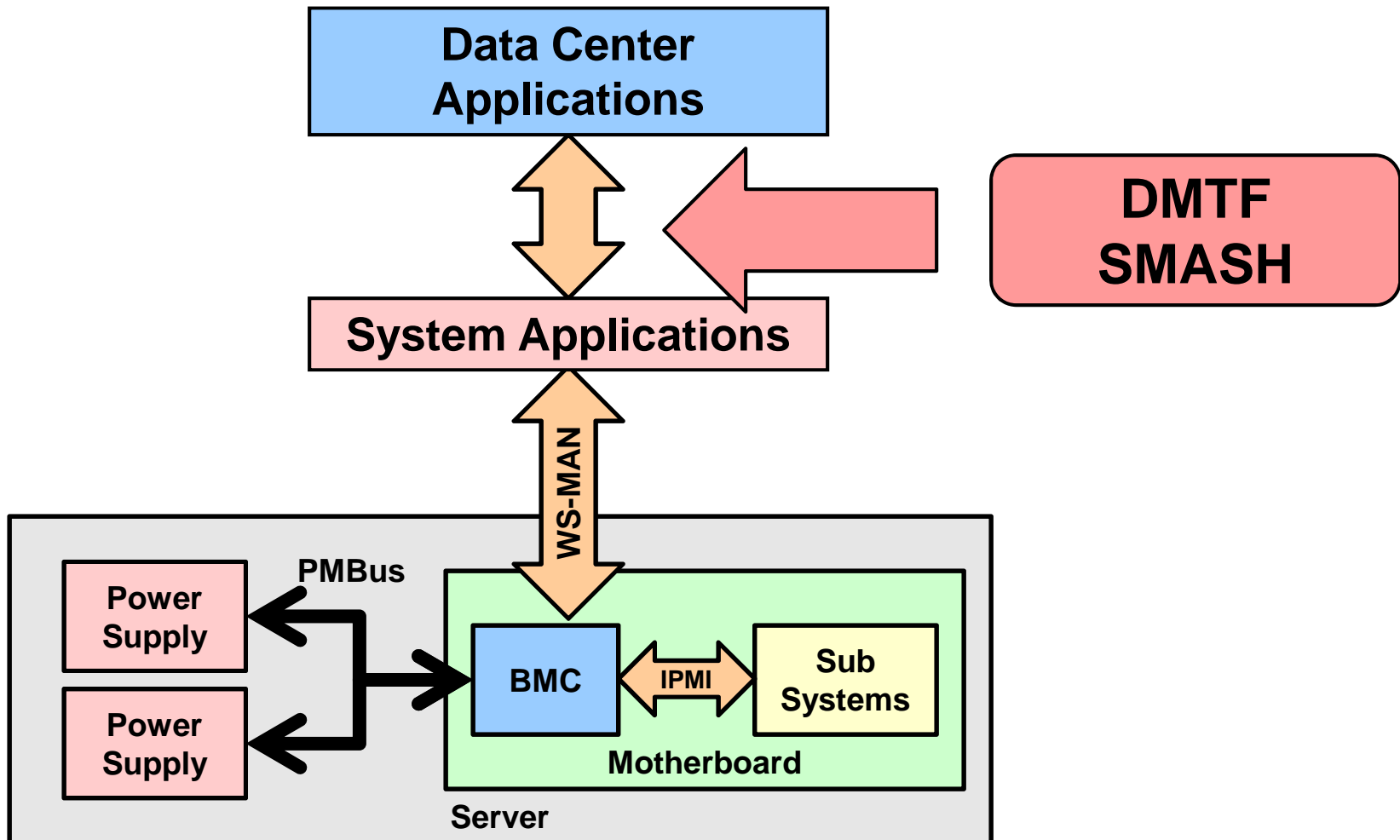

PMBus In Data Center

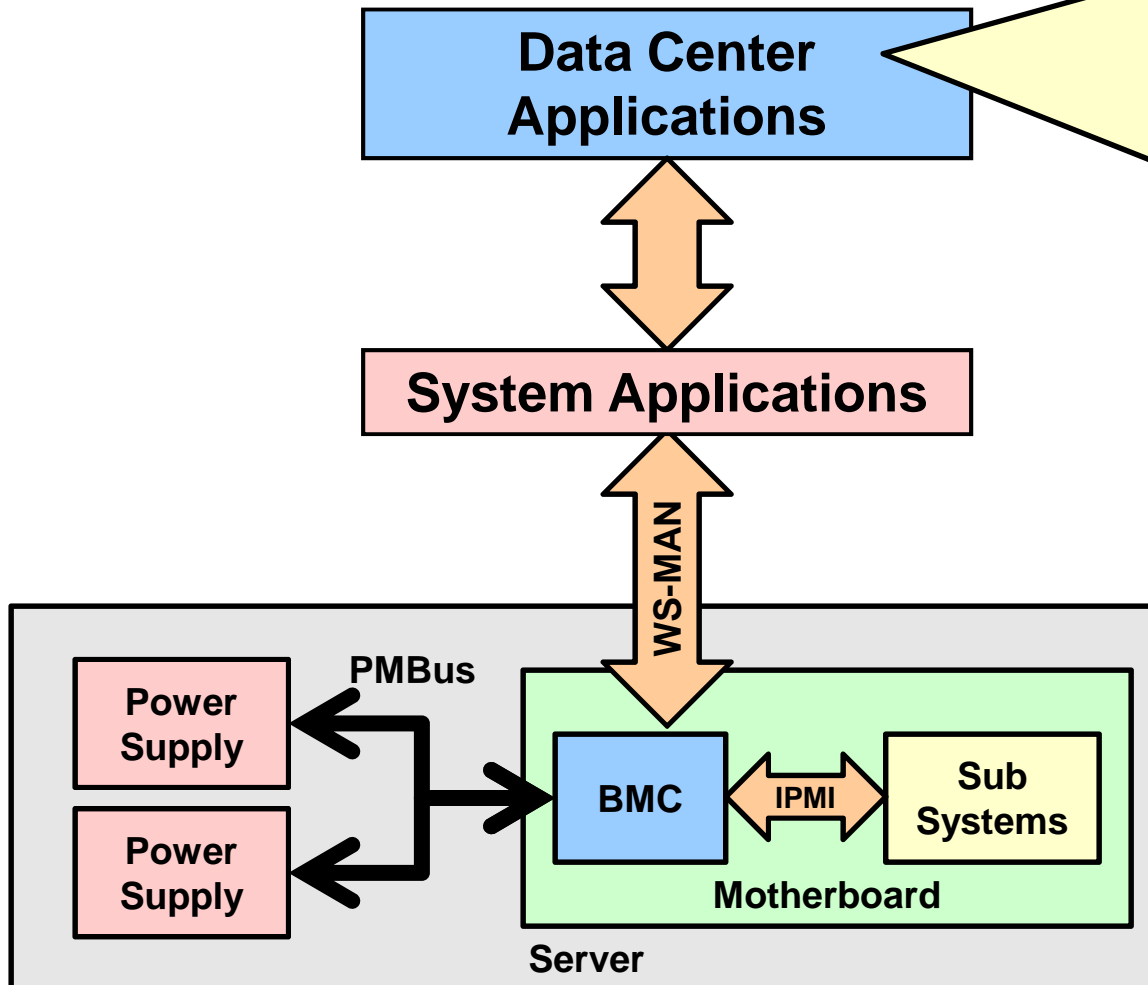

- Charge Back
 - Track Energy Consumption
- Thermal Mgt
 - Protect Against Hot Spots
- Circuit Mgt
 - Protect Against Breaker Overload

PMBus In A Next Gen Server

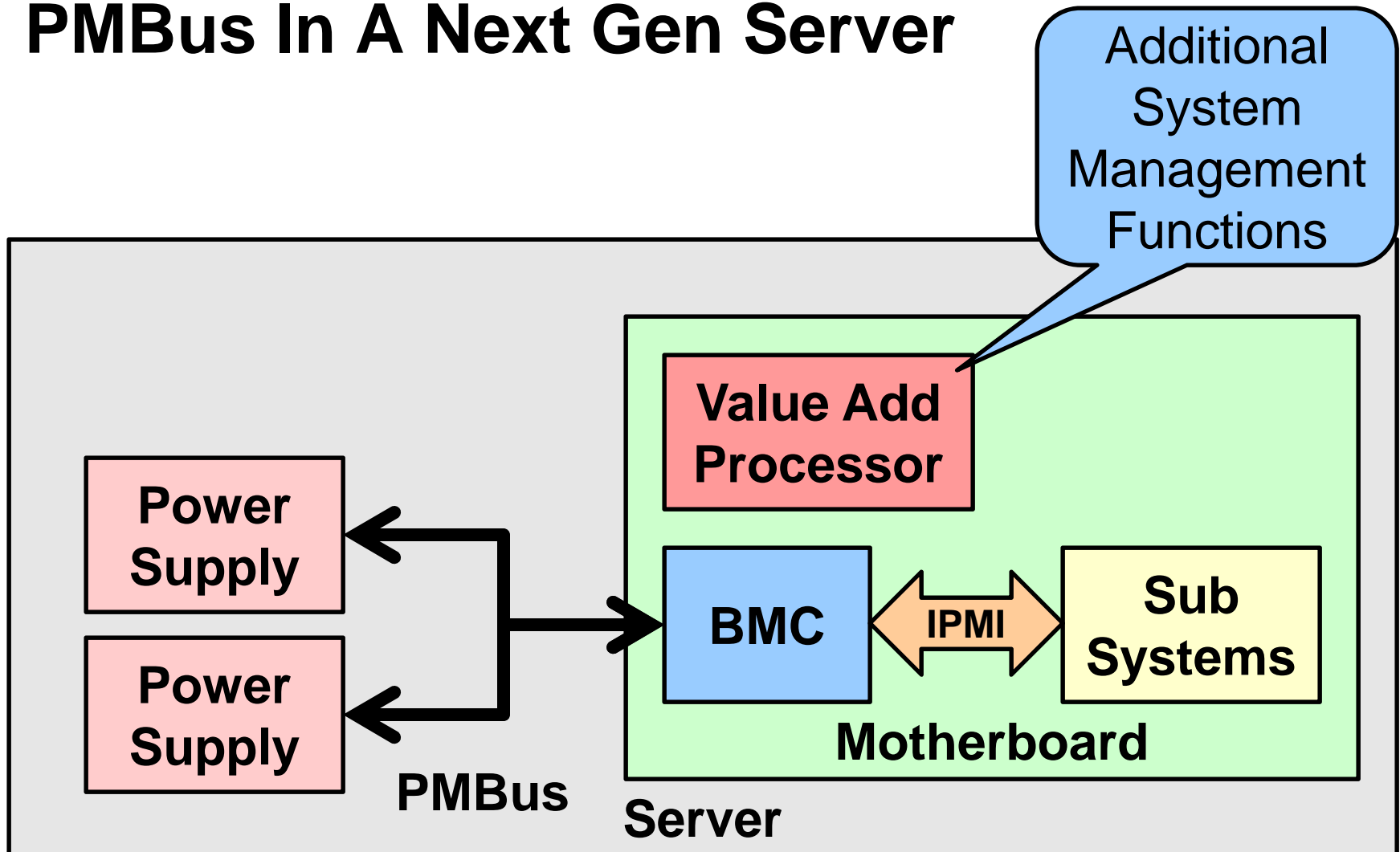

PMBus In A Next Gen Server

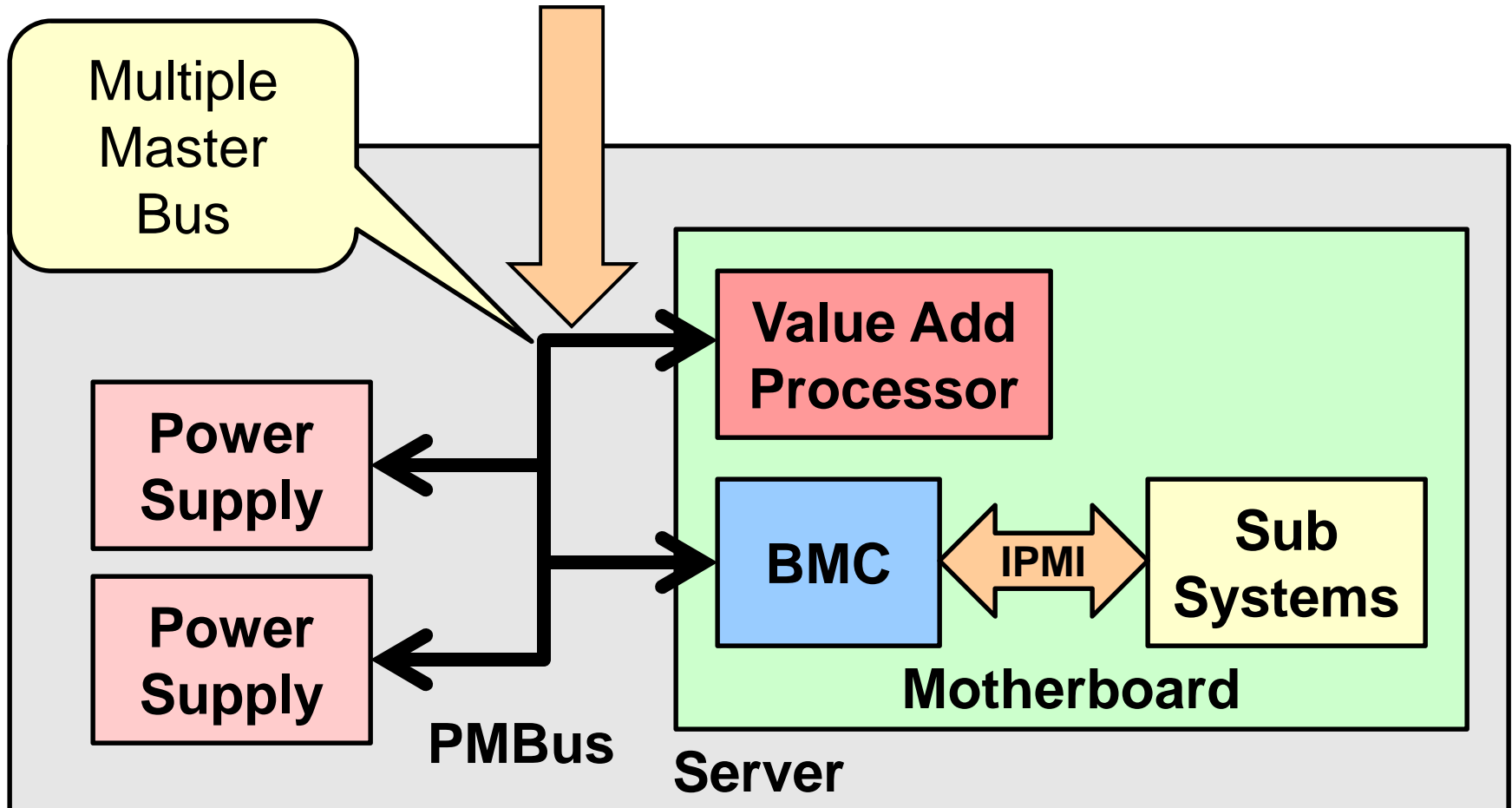

Multiple Output Power Supplies

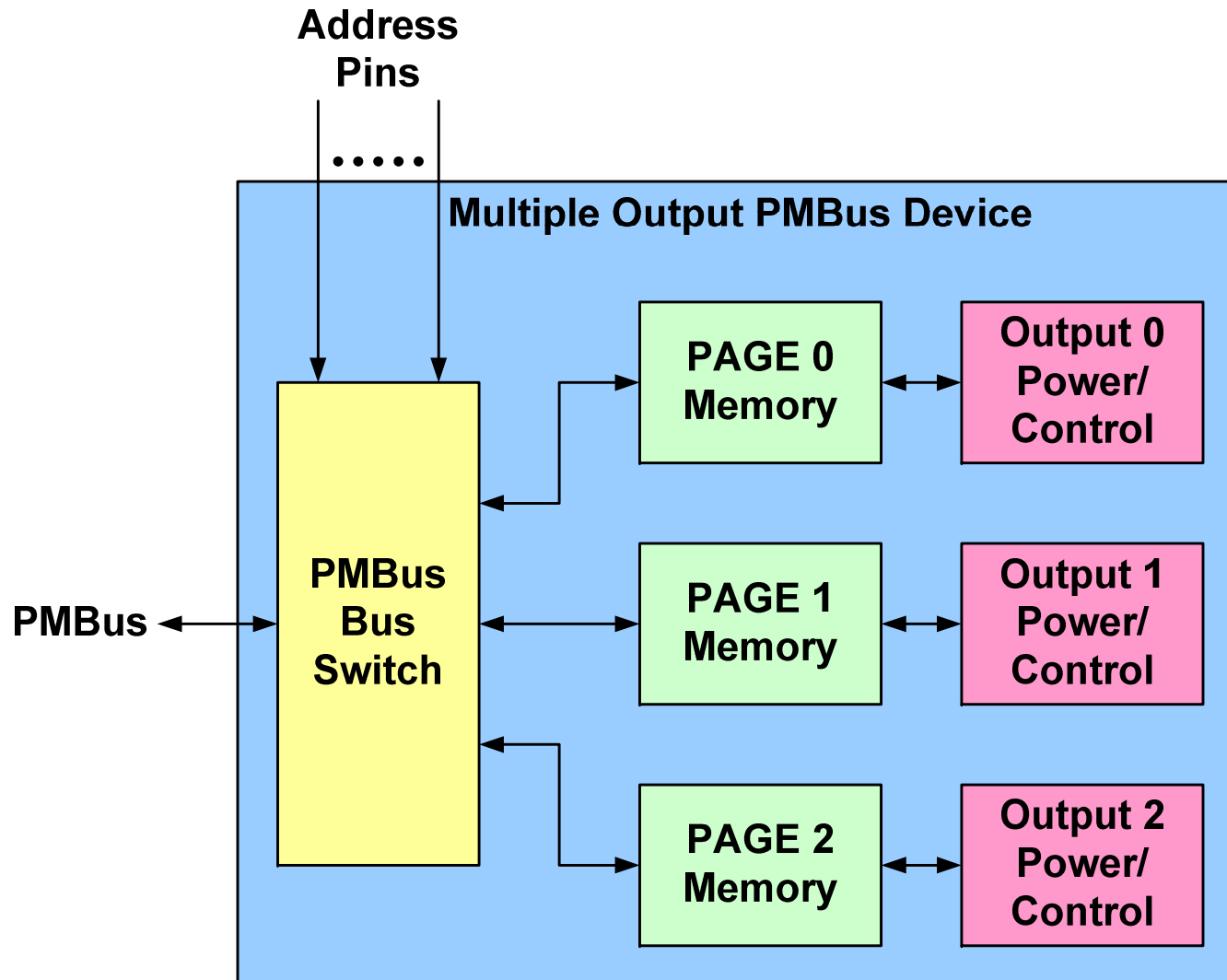

Multiple Output Power Supplies

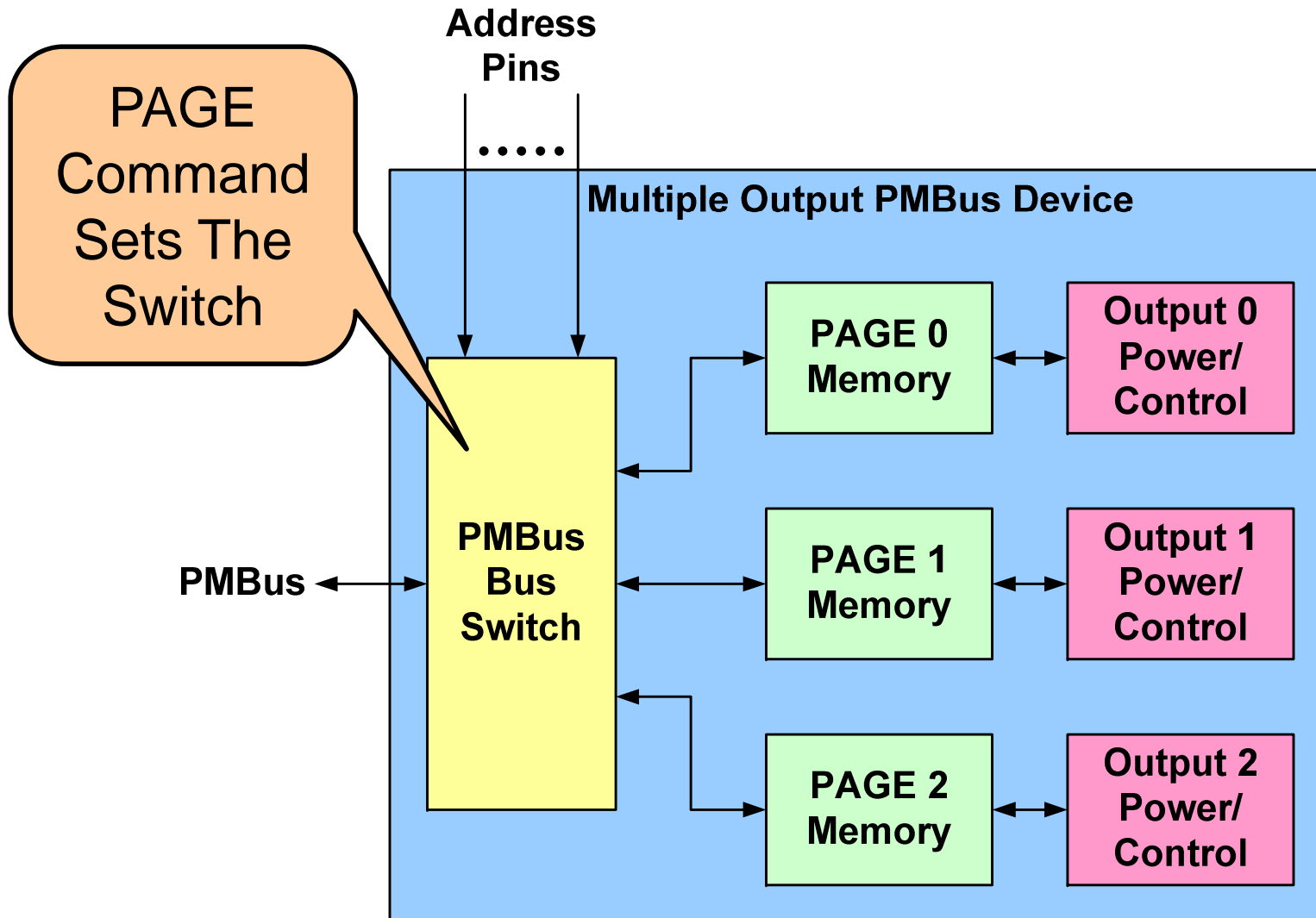

Multiple Output Power Supplies

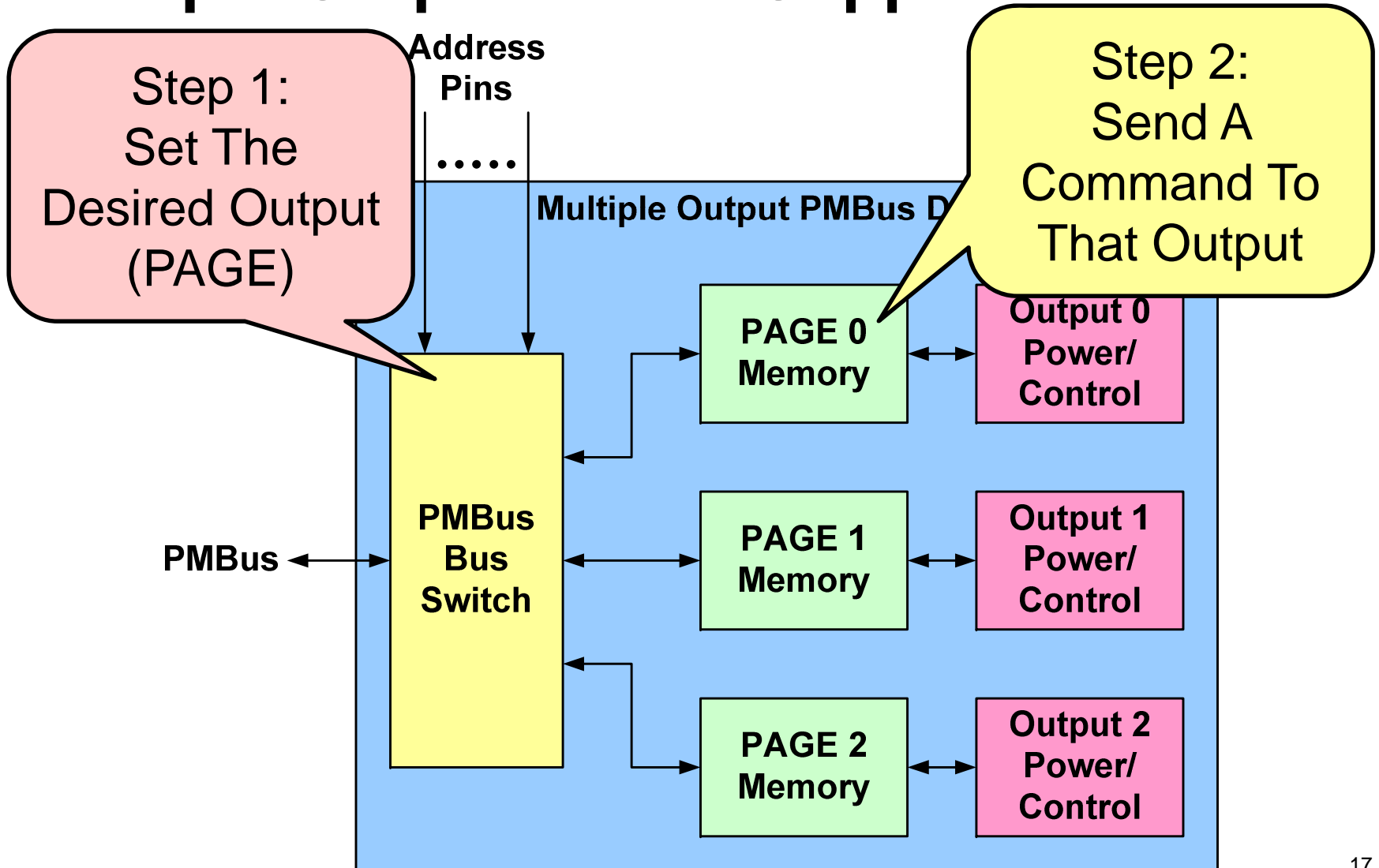

Potential Conflict

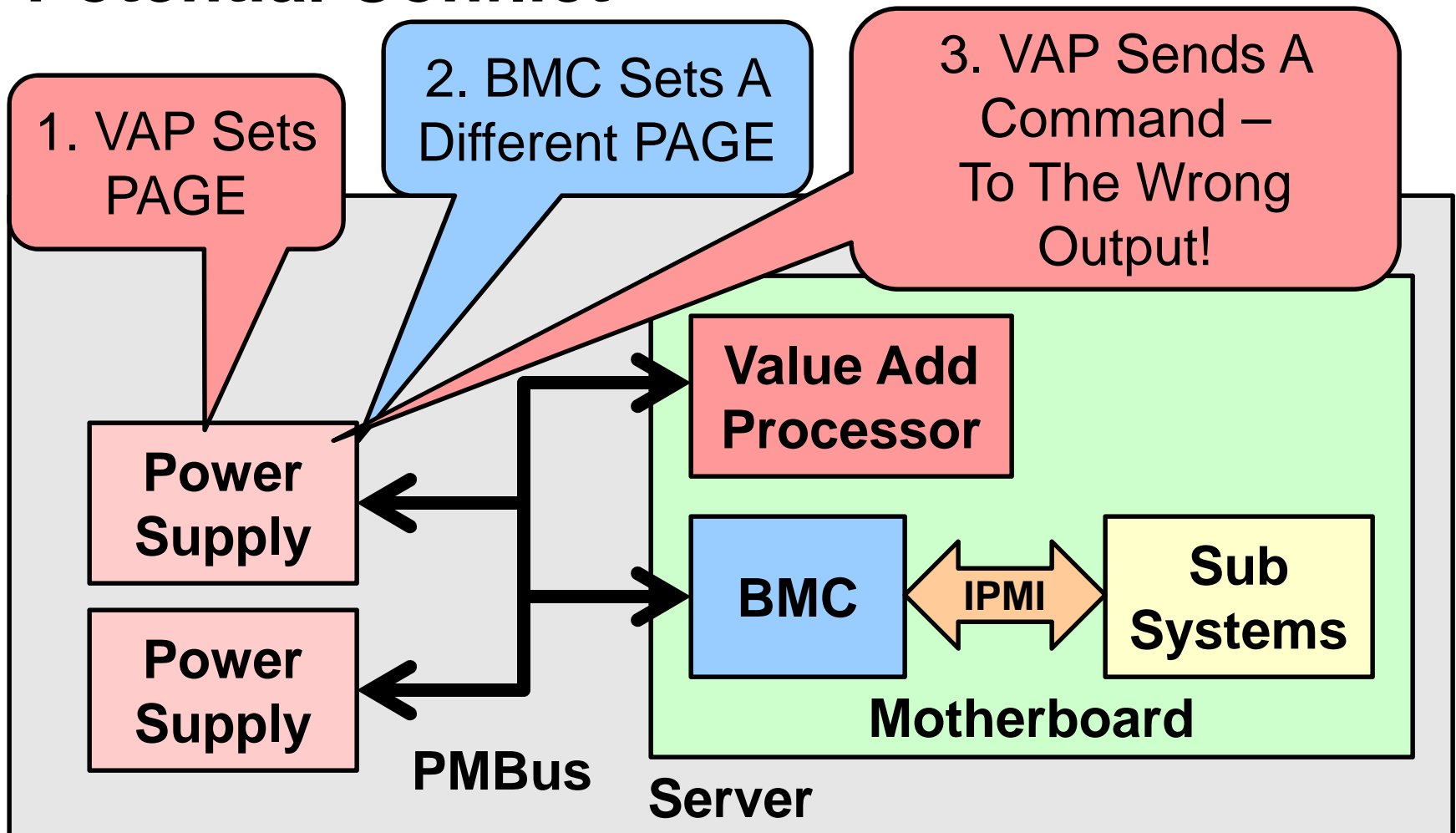

PAGEPLUS

- New Command: PAGE PLUS
- Transmit In One Bus Transaction
 - Device Address
 - Set The PAGE
 - Send A Command To That Page
 - Write Or Read Data Related To That Command

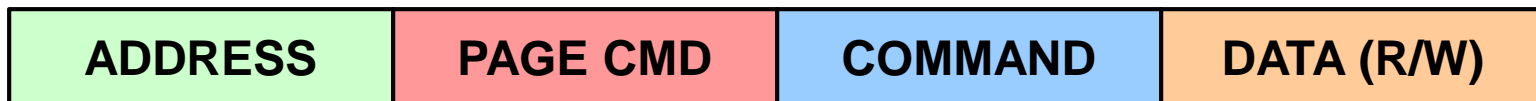

Another Potential Conflict

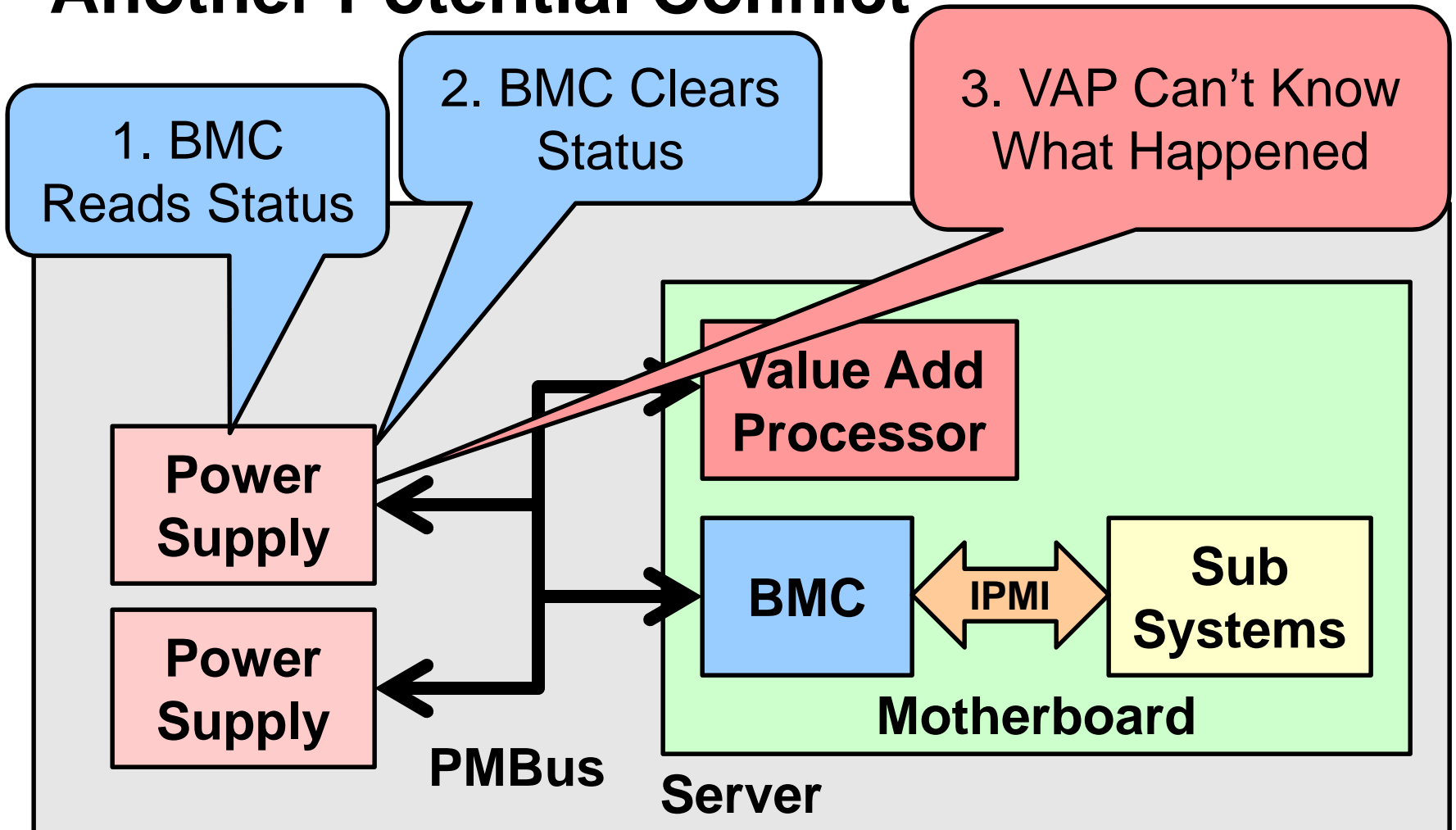

Another Potential Conflict

Why Can't These Two Processors Talk To Each Other?

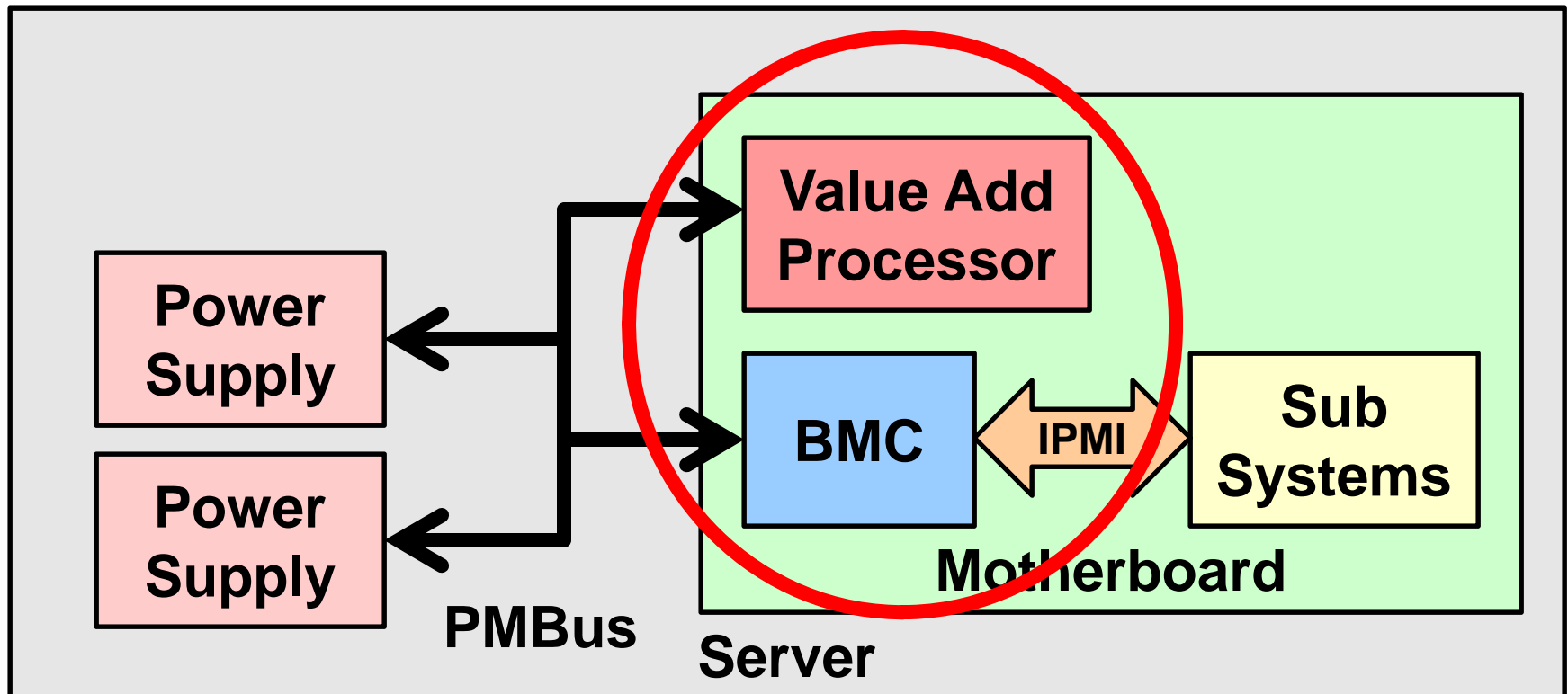

Duplicate Status Information

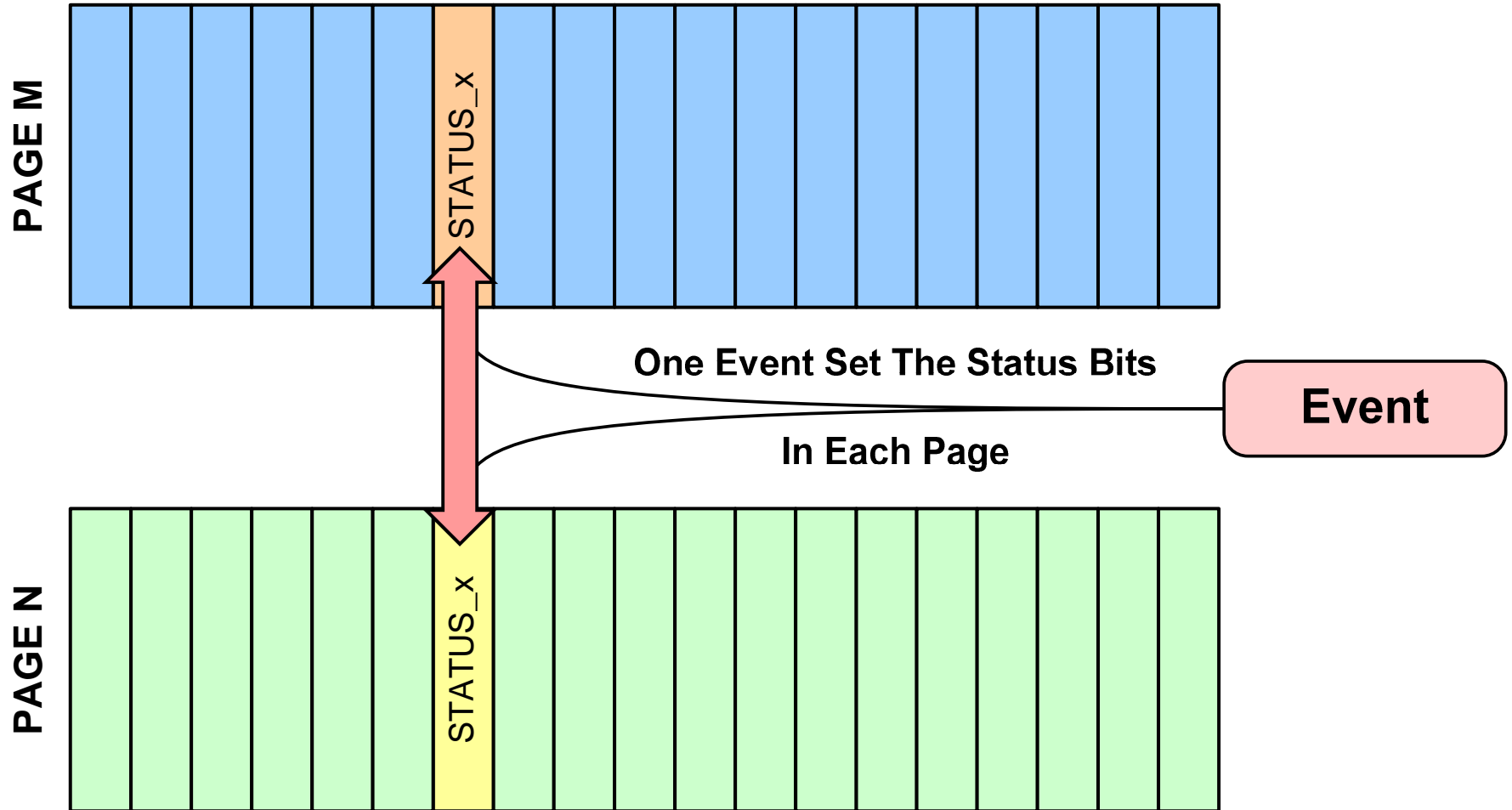

Bits Set Together/Cleared Individually

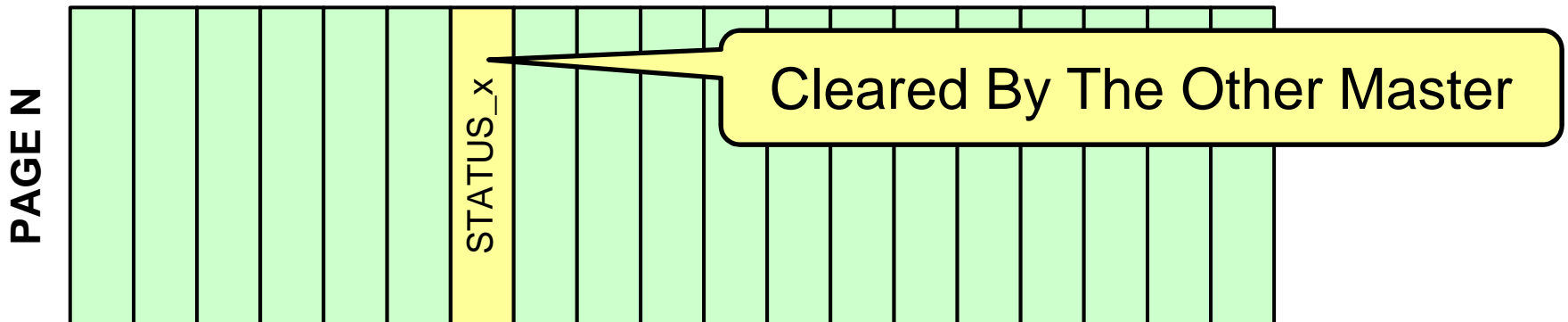
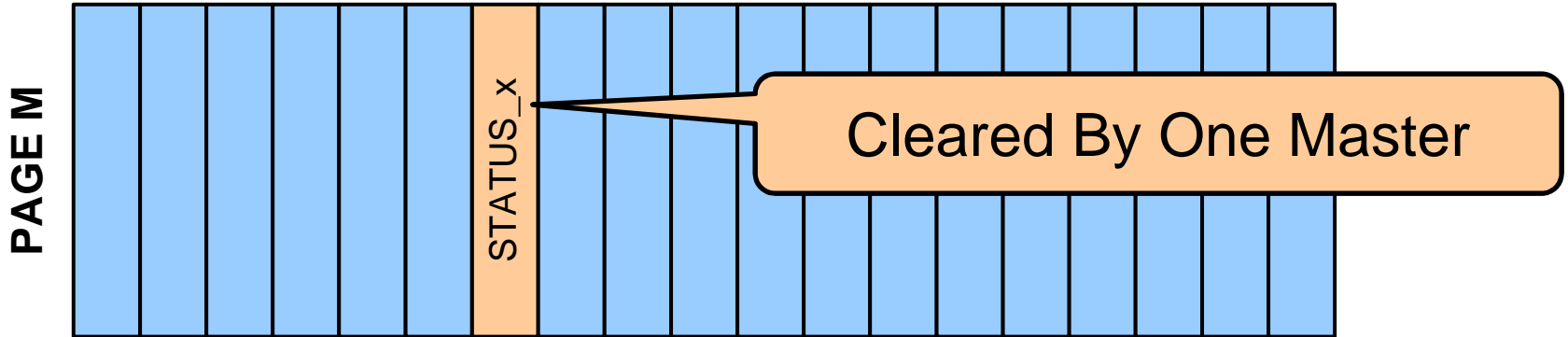

Reading Input And Output Power

- PMBus Has READ_POUT And READ_PIN Commands
- But...
- Getting Good Values For Power Is Problematic
- Issues
 - Averaging Time
 - Data Age
 - Averaging Calculation Methods
- OEMS Are Looking For Accuracy Of 1-2%

Reading Input And Output Power

- PMBus Has READ_POUT And READ_PIN Commands
- But...
- Getting Good Values For Power Is Problematic
- Issues
 - Averaging Time
 - Data Age
 - Averaging Calc
- OEMS Are Looking For Accuracy Of 1-2%

“Sampling And Averaging
Considerations For Measuring
AC Input Power”
APEC 2009

READ_EIN And READ_EOUT

- Revision 1.2 Will Have Two New Commands:
READ_EIN And READ_EOUT
- Attempt Is To Make Reporting Of Power
 - Independent Of PMBus Device Characteristics
 - Put Computation Burden On Host
 - Put Time Keeping Burden On Host

Power Calculation

- Commands Will Return Two Values
 - An Accumulated Energy Reading (“Watt-Samples”)
 - Current Number Of Power Samples
- Discrete Time Power Calculation

$$P_{AVE} = \frac{1}{N} \sum_{n=1}^N p[n] = \frac{1}{N} \sum_{n=1}^N v[n] \cdot i[n]$$

Power Calculation

- Host Keeps At Least The Last Values Returned
 - With Time Stamp Information If Needed
 - Rollover Tracking Are The Host's Responsibility
- Host Retrieves Accumulator And Sample Count When It Wants
- Host Calculates The Average Power Since The Last Reading By:

$$P_{AVERAGE} = \frac{\text{Latest Accumulator Count} - \text{Previous Accumulator Count}}{\text{Latest Sample Count} - \text{Previous Sample Count}}$$

Conceptual Implementation

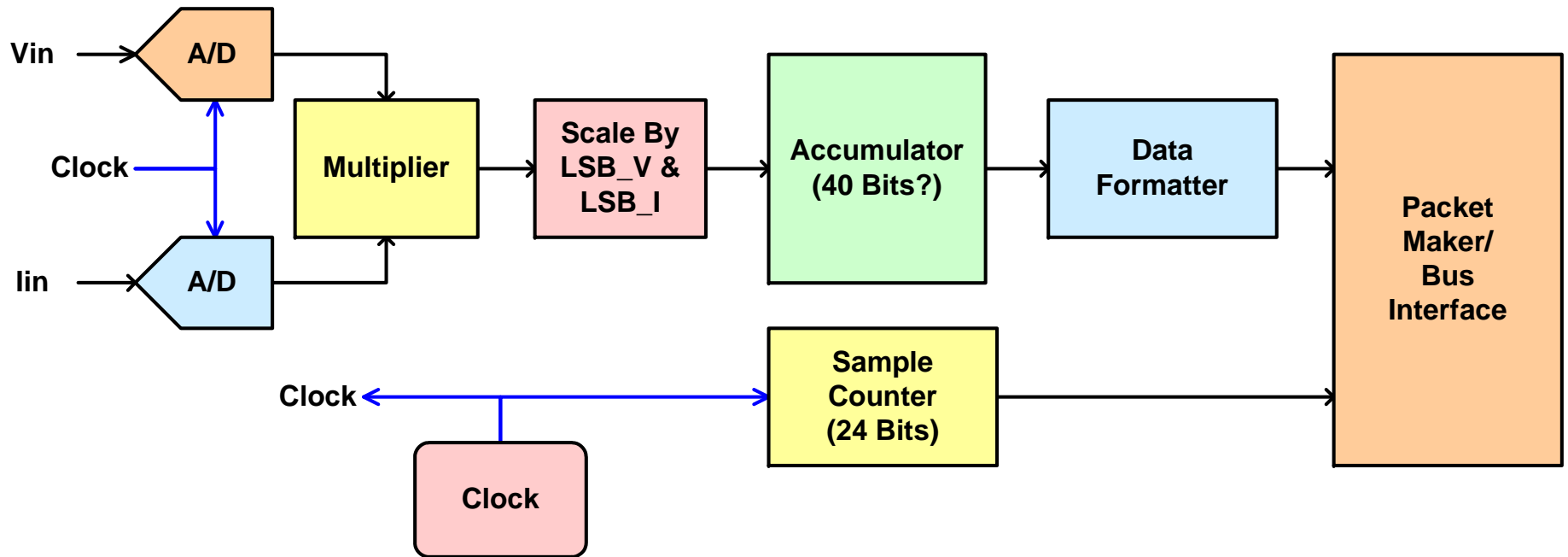

Clarify Status Bits/SMBALERT#

- Comments Received That Specification Is Not Clear On How Status Bits Are:
 - Set
 - Cleared
 - Interact With SMBALERT# Signal

Conceptual Schematic

Looking At Using A Conceptual Schematic To Convey Functionality

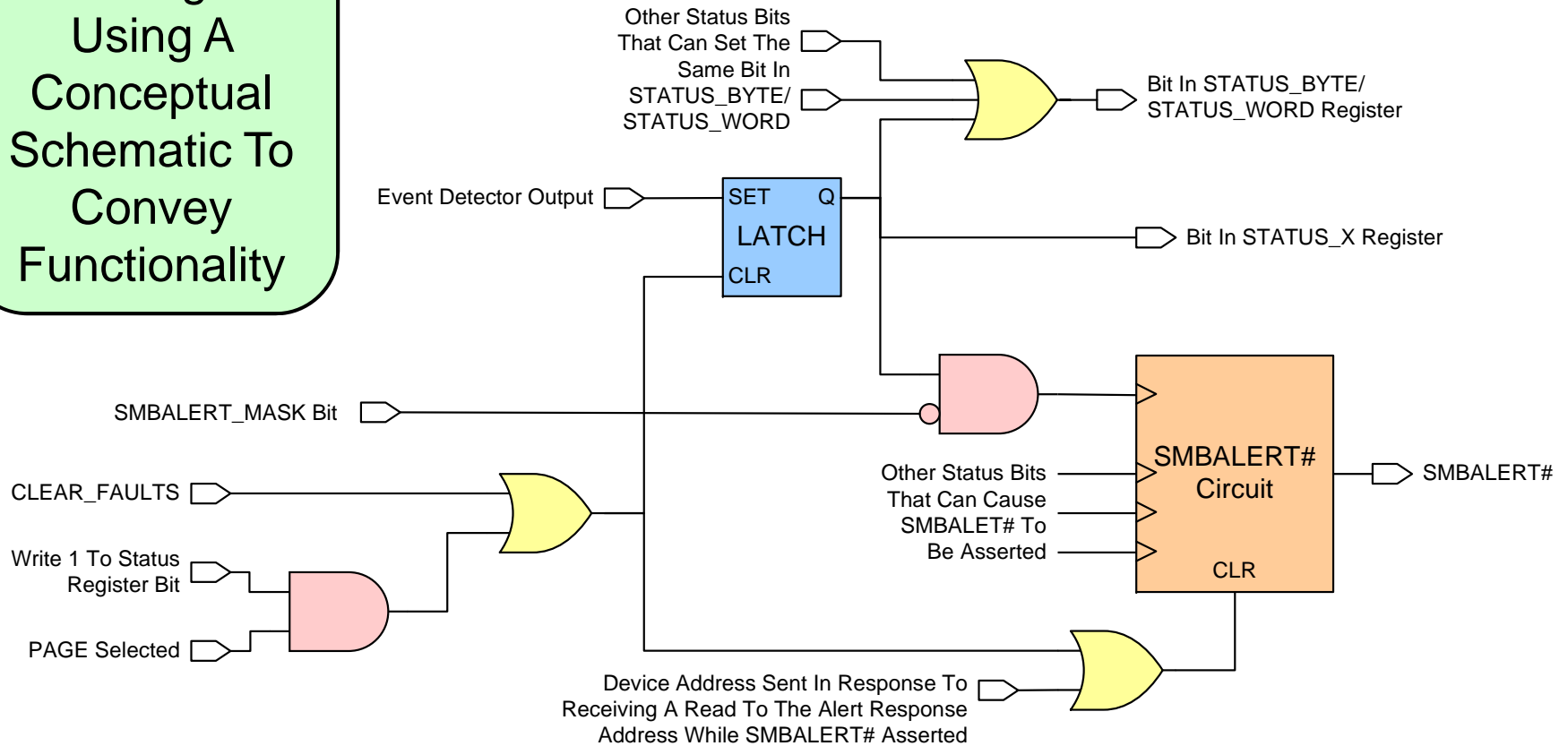

Conceptual Schematic

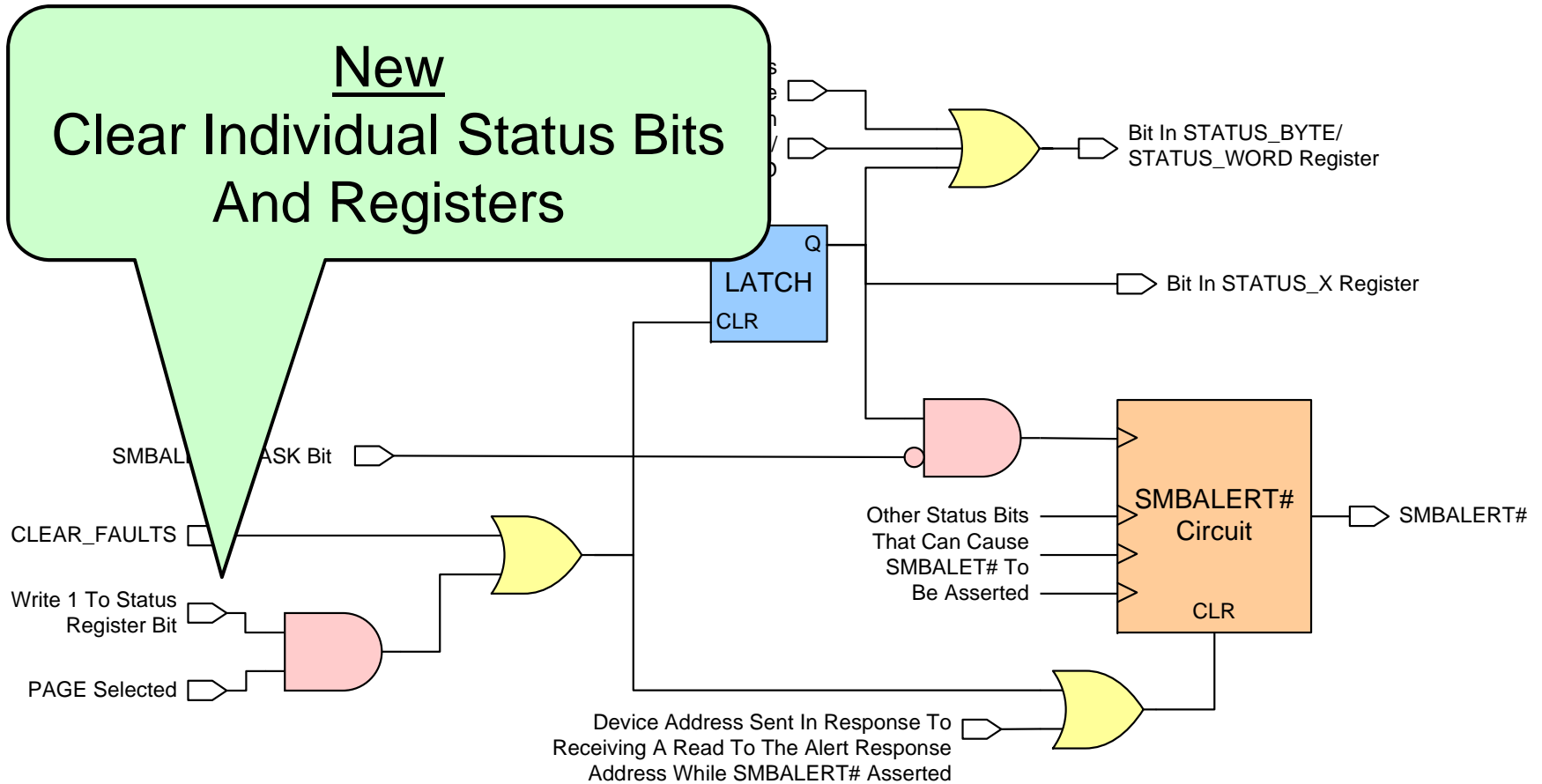

Other Changes

- Now Based On SMBus V2.0
- Bus I/O High Impedance When Device Is Off
- Group Protocol PEC Clarified
- IOOUT_CAL_GAIN Updated
- MFR_MAX_TEMP_1,2,3 Command

Not The Complete List!

Acknowledgment

Thanks To Brian Griffith Of Intel Corporation
For Contributions On “PMBus In A Server”,
“PMBus In the Data Center” And Server
Power Application Profile

**Thank You
For Your Time
And Attention**